

Table of Contents

Table of Contents.....	1
Preface.....	1
Chapter 1 Installation.....	2
Unpacking.....	2
Connecting the LCD Monitor and Base.....	2
Viewing Angle Adjustment.....	2
Detaching LCD Monitor from Its Stand.....	3
Interface for Arm Applications.....	3
Connecting the Display.....	3
Connecting the AC Power.....	3
Connecting the Audio Cable.....	3
Setting Up the LCD Monitor.....	3
Power Management System.....	3
Chapter 2 Display Controls.....	4
User Controls.....	4
Adjusting the Monitor's Display.....	4
Function Description.....	5
Chapter 3 Technical Information.....	7
Specifications.....	7
Standard Timing Table.....	9
Troubleshooting.....	10

Preface

This manual is designed to assist users in setting up and using the LCD Monitor. Information in this document has been carefully checked for accuracy; however, no guarantee is given to the correctness of the contents. The information in this document is subject to change without notice. This document contains proprietary information protected by copyright. All rights are reserved. No part of this manual may be reproduced by any mechanical, electronic or other means, in any form, without prior written permission of the manufacturer.

FCC Class B Radio Frequency Interference Statement

This equipment has been tested and found to comply with the limits for a Class B digital device, pursuant to Part 15 of the FCC Rules. These limits are designed to provide reasonable protection against harmful interference in a residential installation. This equipment generates, uses, and can radiate radio frequency energy, and if not installed and used in accordance with the instruction, may cause harmful interference to radio communications. However, there is no guarantee that interference will not occur in a particular installation. If this equipment does cause harmful interference to radio or television reception, which can be determined by turning the equipment off and on, the user is encouraged to try to correct the interference by one or more of the following measures:

- Reposition or relocate the receiving antenna.
- Increase the separation between the equipment and the receiver.
- Connect the equipment into an outlet on a circuit different from that to which the receiver is connected.
- Consult the dealer or an experienced monitor technician for help.

The device complies with Parts 15 of the FCC Rule. Operation is subject to the following two conditions: (1) this device may not cause harmful interference; and (2) this device must accept any interference received, including interference that may cause undesired operations.

Canadian DOC Notice



This Class B digital apparatus meets all requirements of the Canadian Interference-Causing Equipment Regulations.
Cet appareil numérique de la classe B respecte toutes les exigences du Règlement sur le matériel brouilleur du Canada.

CE Notice (European Union)



This device complies with the requirements set out in the Council Directive on the Approximation of the Laws of the Member States relating to Electromagnetic Compatibility Directive 89/336/EEC, Amended by 92/31/EEC and 93/68/EEC and Low Voltage Directive 73/23/EEC. For the evaluation regarding the Electromagnetic Compatibility, the Following standards are applied:

LVD: EN60950_1
EMC: EN55022, EN55024, EN61000-3-2, EN61000-3-3

Important Safety Instructions

Please read the following instructions carefully. This manual should be retained for future use.

- To clean LCD Monitor screen;
 - Power off LCD Monitor and unplug the AC Cord.
 - Spray a non-solvent cleaning solution onto a rag.
 - Gently clean the screen with dampened rag.
- Do not place the LCD Monitor near a window. Exposing the monitor to rain water, moisture or sunlight can severely damage it.
- Do not apply pressure to the LCD screen. Excess pressure may cause permanent damage to the display.
- Do not remove the cover or attempt to service this unit by yourself. Servicing of any nature should be performed by an authorized technician.
- Store LCD Monitor in a room with a room temperature of $-20^{\circ} \sim 60^{\circ}\text{C}$ (or $-4^{\circ} \sim 140^{\circ}\text{F}$). Storing the LCD Monitor outside this range could result in permanent damage.
- If any of the following occurs, immediately unplug your monitor and call an authorized technician.
 - * Monitor to PC signal cable is frayed or damaged.
 - * Liquid spilled into LCD Monitor or the monitor has been exposed to rain.
 - * LCD display or the case is damaged.
- Only use the supplied main power cable to connect the monitor. For a nominal current up to 6A and a device weight above 3 kg, a line not lighter than H05VV-F, 3G, 0.75 mm² must be used.

Lamp Disposal



LAMP(S) INSIDE THIS PRODUCT CONTAIN MERCURY AND MUST BE RECYCLED OR DISPOSED OF ACCORDING TO LOCAL, STATE OR FEDERAL LAWS. FOR MORE INFORMATION, CONTACT THE ELECTRONIC INDUSTRIES ALLIANCE AT WWW.EIAE.ORG. FOR LAMP SPECIFIC DISPOSAL INFORMATION CHECK WWW.LAMPRECYCLE.ORG.

Chapter 1 Installation

Unpacking

Before unpacking the LCD Monitor, prepare a suitable workspace for your Monitor and computer. You need a stable and clean surface near a wall power outlet. Make sure that LCD Monitor has enough space around it for sufficient airflow. Though the LCD Monitor uses very little power, some ventilation is needed to ensure that the Monitor does not become too hot.

After you unpack the LCD Monitor, make sure that the following items were included in the box:

- | | | |
|--|---------------------------|--------|
| * LCD Monitor | * User's Manual | * Base |
| * Monitor-to-PC VGA Cable | * Stereo Jack Audio Cable | |
| * Monitor-to-PC DVI-D Cable (optional) | * Power Cord | |

If you find that any of these items is missing or appears damaged, contact your dealer immediately.

Connecting the LCD Monitor and Base

When you open the box to take the base and put on the desk first. Then connect the LCD Monitor and base please.(See fig.1-1)

You will hear a firm click once the monitor is correctly attached to the base.

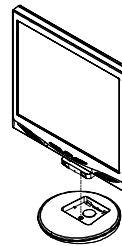

Figure 1-1

Viewing Angle Adjustment

The LCD Monitor is designed to allow users to have a comfortable viewing angle. The viewing angle can be adjusted from -5° to $+20^{\circ}$.(See fig. 1-2)

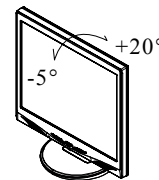

Figure 1-2

Warning

Do not force the LCD Monitor over its maximum viewing angle settings as stated above. Attempting this will result in damaging the Monitor and Monitor stand.

Detaching LCD Monitor from Its Stand

Unscrew screws ❶ the swivel base support column and pull down ❷ the hinge to release.

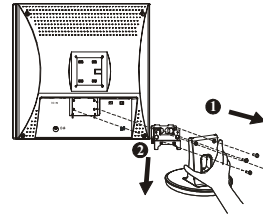

Figure 1-3

Interface for Arm Applications

Before installing to mounting device, please refer to Fig.1-3. The rear of this LCD display has four integrated 4 mm, 0.7 pitches threaded nuts, as well as four 5 mm access holes in the plastic covering as illustrated in Figure 1-4. These specifications meet the **VESA Flat Panel Monitor Physical Mounting Interface Standard** (paragraphs 2.1 and 2.1.3, version 1, dated 13 November 1997).

Note :Please using M 4mm x 10mm (L) screw for this application.

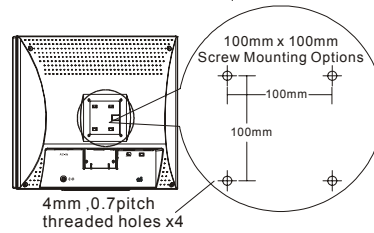

Figure 1-4

Connecting the Display

1. Power off your computer.
2. Connect one end of either the VGA or DVI cable from the PC to the LCD Monitor's matching VGA or DVI port (see fig 1-5)
3. Make sure connections are secure.

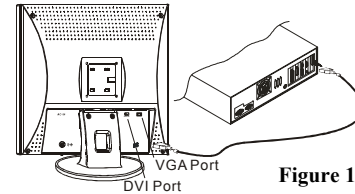

Figure 1-5

Connecting the AC Power

1. Connect the power cord to the LCD Monitor.(See Fig. 1-6)
2. Connect the power cord to an AC power source.

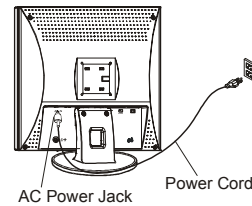

Figure 1-6

Connecting the Audio Cable

1. Connect the audio cable to the "LINE OUT" jack on your PC's audio card or to the front panel's "AUDIO OUT" jack of your CD ROM drive. (See Fig. 1-7)
2. Connect the other end of the audio cable to the LCD Monitor's "LINE IN" jack.

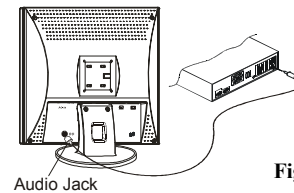

Figure 1-7

Setting Up the LCD Monitor

1. Make sure the AC power cord is connected to the LCD Monitor.
2. Turn on the LCD Monitor's power switch, located on the bezel of the monitor.

Power Management System

This LCD Monitor complies with the VESA DPMS (version 1.0) Power Management guidelines. The VESA DPMS provides four power saving modes through detecting a horizontal or vertical sync. signal. When the LCD Monitor is in power saving mode, the monitor screen will be blank and the power LED indicator will light yellow.

Chapter 2 Display Controls

User Controls

A brief description and the location of all LCD Monitor functions controls and indicators:

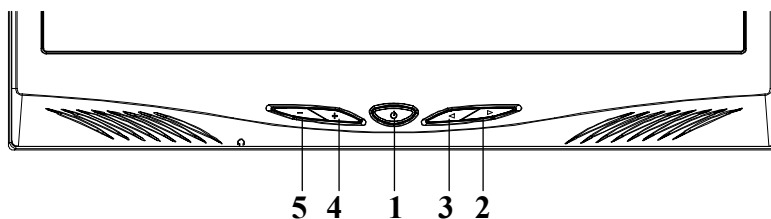

Figure 2-1

- 1 Power LED will be blue when monitor is on, be yellow when in power saving mode, be dark when monitor in off mode. Power ON/OFF switch for push to ON and push to OFF (Toggle switch)
- 2 Menu / Function select (clockwise)
- 3 Auto Sync / Function select (counter-clockwise)
- 4 Audio Volume Function / Adjustment increase
- 5 Audio Mute ON-OFF Selection / Adjustment decrease

Adjusting the Monitor's Display

The monitor has four function control buttons to select among functions shown on OSD menu, designed for easy user-viewing environments.

OSD Function Menu

To access OSD Main menu, simply press one of the Function Select control buttons, and the menu diagram will pop up on the screen as shown on Fig. 2-2:

Continue pressing the Function Select buttons to scroll through the entire menu then press Adjustment Control buttons to adjust content of selected item.



















Figure 2-2

Attention

Firmware revision may have been updated into a latest version while the version number shown on all OSD menus in this manual will stay as Ver. 1.00.

Function Description

Icon	Function	Function Description
	Brightness	Scales of brightness are available to choose from (0 to 100).
	Contrast	Scales of contrast are available to choose from (0 to 100).
	H. Position	This function let's you adjust the display's horizontal position
	V. Position	This function let's you adjust the display's vertical position.
	Sharpness	This function let's you select the images sharpness. Five selections are available. A smoother setting is more suitable for pictures, while a sharper setting is more suitable for text.
	OSD Transparency	This function let's you set the transparency of the OSD menu. The transparency is adjustable from 0 to 3. 4 scales are available.
	Phase	Adjusts the focus and clarity of the display.
	Clock	This function carries a frequency-tracking feature that offers users better stability and clarity. The adjustable range can be variable in different modes. This function records the deviated number of clock period between input timing and supported timing. The clock value may not be "0" after Auto Sync when the input timing is different from supported timing.
	Color Temperature	Push the (+/-) button to select a different color temperature. Please see the diagram below for function and description.
	OSD H. Position	This function moves the OSD menu window horizontally.
	OSD V. Position	This function moves the OSD menu window vertically.
	Graph / Text	Because the H and V-Frequencies of both 640 x 400 70Hz, and 720 x 400 70Hz, are the same, this function let's you manually select either 640 x 400 (graphics mode), or 720 x 400 (text mode).
	Recall	The recall function will return all adjusted parameters to factory preset values.
	Language	Nine OSD language options are available: English, German, French, Spanish, Italian, Japan, Russian, Simplified Chinese and Traditional Chinese. Press the left or right adjustment control button to select other language.
	Auto and Input Select	Press ◀ button (+/-) to activate the selected function, Auto Adjustment, Use Analog Input or Use Digital Input. The Auto Adjustment function let you adjust the display size, clock and phase to obtain the best viewing settings. This process will take 3 ~ 5 seconds to complete. Attention: After Auto Adjustment, the display might display wrong position or size, if it has received a pattern which has no screen border. You may select either Analog or Digital Input video when VGA input or/and DVI Input is/are available.
	Exit	Saves the values of this setting and exits the OSD menu function.

Icon	Function	Description
9300	CIE coordinated Color Temperature of 9300°K	Sets the CIE coordinate color temperature to 9300°K
7500	CIE coordinated Color Temperature of 7500°K	Sets the CIE coordinate color temperature to 7500°K
6500	CIE coordinated Color Temperature of 6500°K	Sets the CIE coordinate color temperature to 6500°K
User	Three colors (Red, Green, Blue) can be adjusted from the OSD menu	Sets the settings to a by user defined CIE Temperature.



Notice:

“OSD Lock Out” Function:

When monitor is in normal display, you can enable the “OSD Lock Out” function.

*** How to enter “OSD Lock Out” function =>**

Step 1:

The monitor is displaying after power on.

Step 2:

To press the buttons “VAL -“ and “FUN >” at the same time for 3 seconds or more.

Step 3:

Monitor will show an “OSD Lock Out” message for 5~10 seconds and the message will disappear automatically.

While the monitor is in the state of “OSD Lock Out”, if press OSD button, “OSD Lock Out” message will appear for 5~10 seconds.

*** How to exit “OSD Lock Out” function =>**

Step 1:



When the monitor is in the state of “OSD Lock Out” .

Step 2:

To press the buttons “VAL -“ and “FUN >” at the same time for 3 seconds or more.

Step 3:

Display will show main OSD menu. (Now the monitor already has escaped from “OSD Lock Out” function.)



Chapter 3 Technical Information

Specifications

LCD Panel

Size	19" (48cm)
Display Type	Active matrix color TFT LCD
Resolution	1280 x 1024
0.294" x 0.294"	0.294" x 0.294"
Display Area (mm)	14.82" x 11.85"(H x V)

Display Colors

16.2M with FRC or Dithering

Video

Input Signal	Analog RGB 0.7Vp-p.	Digital TMDS
Input Impedance	75 Ohm ± 2%	
Polarity	Positive, Negative	
Amplitude	0 - 0.7 ± 0.05 Vp	TMDS
Multi-mode Supported	Horizontal Frequency: 24 ~ 80 kHz	24~80KHz
	Vertical Frequency: 56 ~ 75 Hz	56~75 Hz

Control

Power switch (hard and soft types)	On/Off switch with LED indicator
------------------------------------	----------------------------------

AUDIO

INPUT	500m Vrms
OUTPUT	0.5W + 0.5W

OSD

Brightness	Digital
Contrast	Digital
Horizontal Position	Digital
Vertical Position	Digital
Phase	Digital
Clock	Digital
OSD Format	26 characters x 15 rows

Power Management

Mode	Power Consumption*	AC Input	LED Color
On	55 W maximum	240 VAC	Blue
Off	2 W maximum	240 VAC	Yellow
Soft switch off	2 W maximum	240 VAC	Dark
Disconnected	2 W maximum	240 VAC	Yellow: Standby, Suspend, Off Dark: DC Power off

* Meeting VESA DPMS requirements measured from AC Input end of AC power cord.

Sync Input

	<u>Analog</u>	<u>Digital</u>
Signal	Separate TTL compatible horizontal and vertical synchronization	TMDS
Polarity	Positive and negative	--

Plug & Play

Supports VESA DDC2B functions

External Connection

Power Input (AC input)	AC socket
Video Cable	15-pin D-sub connector/Monitor-to-PC DVI-D Cable (optional)
Audio Cable	Stereo Jack

Environment

Operating Condition:	Temperature	5°C to 40°C/41°F to 104°F
-----------------------------	-------------	---------------------------

Relative Humidity 20% to 80%

Storage Condition:

Temperature -20°C to 60° C/-4°F to 140° F
 Relative Humidity 5% to 85%

Power Supply (AC Input)

Input Voltage Single phase, 100 ~ 240VAC, 50 / 60 Hz
 Input Current 1.2 A maximum

Size and Weight

Dimensions 16.6" (W) x 16.8" (H) x 8.7" (D) mm
 Net Weight 20.9 lbs.
 Gross Weight 24.2 lbs.

Pin Assignment

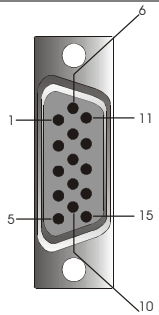
	Signal		Signal	
	PIN	Description	PIN	Description
	1	Red	9	+5V
2	Green	10	Hot Plug Detect	
3	Blue	11	NC	
4	Digital GND	12	SDA	
5	Digital GND	13	H. Sync.	
6	Red Rtn	14	V. Sync.	
7	Green Rtn	15	SCL	
8	Blue Rtn			

For Digital DVI-D connector

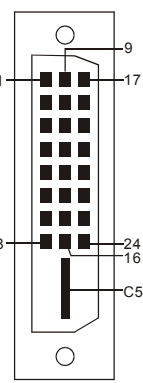
	Signal		Signal		Signal	
	PIN	Description	PIN	Description	PIN	Description
	1	RX2-	10	RX1+	19	Shield for TMDS Channel 0
	2	RX2+	11	Shield for TMDS Channel 1	20	NC
	3	Shield for TMDS Channel 2	12	NC	21	NC
	4	NC	13	NC	22	Shield for TMDS Channel clock
	5	NC	14	+5V	23	RXC+
	6	SCL	15	Hot Plug Detect	24	RXC-
	7	SDA	16	HPD	C5	NC
	8	NC	17	RX0-	C6	NC
9	RX1-	18	RX0+			

Standard Timing Table

If the selected timing is NOT included in table below, this LCD monitor will use the most suitable available timing.

TIMING	FH(kHZ) FV(HZ)	SYNC POLARITY	TOTAL (DOT/ LINE)	ACTIVE (DOT/ LINE)	SYNC WIDTH (DOT/LINE)	FRONT PORCH (DOT/LINE)	BACK PORCH (DOT/LINE)	PIXEL FOREQ (MHZ)
640x350	31.469	+	800	640	96	16	48	25.175
VGA-350	70.087	-	449	350	2	37	60	
640x400	24.83	-	848	640	64	64	80	21.05
NEC PC9801	56.42	-	440	400	8	7	25	
640x400	31.469	-	800	640	96	16	48	25.175
VGA-GRAPH	70.087	+	449	400	2	12	35	
640x400	31.5	-	800	640	64	16	80	25.197
NEC PC9821	70.15	-	449	400	2	13	34	
640X480	31.469	-	800	640	96	16	48	25.175
VESA-PAL	50.030	-	629	480	2	62	85	
640x480	31.469	-	800	640	96	16	48	25.175
VGA-480	59.94	-	525	480	2	10	33	
640x480	35.00	-	864	640	64	64	96	30.24
APPLE MAC-480	66.67	-	525	480	3	3	39	
640x480	37.861	-	832	640	40	16	120	31.5
VESA-480-72Hz	72.809	-	520	480	3	1	20	
640x480	37.5	-	840	640	64	16	120	31.5
VESA-480-75Hz	75	-	500	480	3	1	16	
720x400	31.469	-	900	720	108	18	54	28.322
VGA-400-TEXT	70.087	+	449	400	2	12	35	
832x624 APPLE	49.725	-	1152	832	64	32	224	57.2832
MAC-800	74.55	-	667	624	3	1	39	
800x600	35.156	+	1024	800	72	24	128	36
SVGA	56.25	+	625	600	2	1	22	
800x600	37.879	+	1056	800	128	40	88	40
VESA-600-60Hz	60.317	+	628	600	4	1	23	
800x600	48.077	+	1040	800	120	56	64	50
VESA-600-72Hz	72.188	+	666	600	6	37	23	
800x600	46.875	+	1056	800	80	16	160	49.5
VESA-600-75Hz	75	+	625	600	3	1	21	
1024x768	48.363	-	1344	1024	136	24	160	65
XGA	60.004	-	806	768	6	3	29	
1024x768	53.964	+	1328	1024	176	16	112	71.664
COMPAQ-XGA	66.132	+	816	768	4	8	36	
1024x768	56.476	-	1328	1024	136	24	144	75
VESA-768-70Hz	70.069	-	806	768	6	3	29	
1024x768	60.023	+	1312	1024	96	16	176	78.75
VESA-768-75Hz	75.029	+	800	768	3	1	28	
1024x768	60.24	-	1328	1024	96	32	176	80
APPLE MAC-768	75.02	-	803	768	3	3	29	
1152x864	54.054	+	1480	1152	96	40	192	80
(60Hz)	59.270	+	912	864	3	13	32	
1152x864	63.851	+	1480	1152	96	32	200	94.499
(70Hz)	70.012	+	912	864	3	1	44	
1152x864	67.50	+	1600	1152	128	64	256	108.00
(75Hz)	75.00	+	900	864	2	2	32	
1280x960	60.00	+	1800	1280	112	96	312	108.00
(60Hz)	60.00	+	1000	960	3	1	36	
1280x960	70.00	+	1800	1280	112	96	312	126.00
(70Hz)	70.00	+	1000	960	3	1	36	
1280x960	75.00	+	1800	1280	112	96	312	135.00
(75Hz)	75.00	+	1000	960	3	1	36	
1280x1024VESA-	64	+	1688	1280	112	48	248	108
1024-60Hz	60	+	1066	1024	3	1	38	
1280x1024VESA-	80	+	1688	1280	144	16	248	135
1024-75Hz	75	+	1066	1024	3	1	38	

Note: Mode 640x350, 640x400 and 720x400 will locate on middle position but cannot be expanded to full screen on vertical direction.

Troubleshooting

This LCD Monitor has pre-adjusted using factory standard VGA timings. Due to the output timing differences among various VGA cards in the market, users may initially experience an unstable or unclear display whenever a new display mode or new VGA card is selected.

Attention

This LCD Monitor Supports Multiple VGA Modes.

Refer to the Standard Timing Table for a listing of modes supported by this LCD Monitor.

PROBLEM Picture is unclear and unstable

The picture is unclear and unstable, please perform the following steps:

1. Enter PC to "Shut Down Windows" status while you're in MS-Windows environment.
2. Check the screen to see if there's any black vertical stripes appear. If there are, take advantage of the "Clock" function in OSD menu and adjust (by increment or decrement numbers) until those bars disappear.
3. Move to "Phase" function in OSD menu again and adjust the monitor screen to its most clear display.
4. Click "No" on "Shut Down Windows" and back to the normal PC operating environment.

PROBLEM There is no picture on LCD Monitor

If there's no picture on the LCD Monitor, please perform the following steps:

1. Make sure the power indicator on the LCD Monitor is ON, all connections are secured, and the system is running on the correct timing. Refer to Chapter 3 for information on timing.
2. Turn off the LCD Monitor and then turn it back on again. If there is still no picture, press the Adjustment Control button several times.
3. If step 2 doesn't work, connect your PC system to another external CRT. If your PC system Functions properly with a CRT Monitor but it does not function with the LCD Monitor, the output timing of the VGA card may be out of the LCD's synchronous range. Please change to an alternative mode listed in the Standard Timing Table or replace the VGA card, and then repeat steps 1 and 2.

PROBLEM There is no picture on LCD Monitor

If you have chosen an output timing that is outside of the LCD Monitor's synchronous range (Horizontal: 24 ~ 80 kHz and Vertical: 56 ~ 75 Hz), the OSD will display a "**Out of Range**" message. Choose a mode that is supported by your LCD Monitor.

Also, if the signal cable is not connected to LCD monitor at all or properly, the monitor screen will display a message "**No Input Signal**".